



**INSTALLATION AND TROUBLE SHOOTING  
MANUAL for all Models of Nova Kool  
AC/DC and DC only  
Refrigerators and Freezers.**

Thank you for choosing Nova Kool for your refrigeration needs. For over 20 years we have been providing quality DC & AC/DC products for mobile, off power grid and energy conscious installations around the world.

Each unit goes through a battery of tests to ensure strict compliance with our quality policy “Strive for continual improvement of all business processes while involving all associates in the management of quality”. Your unit has been run test at the plant for a minimum of 12hrs, followed by a series of inspections and electrical tests to ensure the quality, the reliability and the safety of your unit.

All Nova Kool units are covered by a 2-year parts warranty that commences upon delivery of the unit to the end user customer.

Please take the time to fill in the information below which can be found on the inside of your new refrigerator. This will help when phoning for service or warranty information.

**Model #** \_\_\_\_\_  
**Serial #** \_\_\_\_\_  
**Date of Purchase:** \_\_\_\_\_  
**Date of Del of Vessel:** \_\_\_\_\_  
**(Or vehicle where applicable)**  
**Selling dealer:** \_\_\_\_\_

Our service department can be reached at 604-523-6515 ext 104, or at [support@novakool.com](mailto:support@novakool.com) from 7:00am to 5:00pm PST

## Thermostat operation:

All Nova Kool units are supplied with a wide range thermostat that is designed to sense the evaporator (cold plate) temperature. The coldest position on the thermostat is reached by turning the knob to the right (clockwise); conversely turning the thermostat knob to the left (counterclockwise) yields a warmer setting.



The OFF position is reached by turning hard counterclockwise past the click. The reference point is shown with an indicator sticker beside the knob.

## Start-up:

The unit is ready to run as shipped. After following the electrical installation information found in this manual, turn the power on and set the thermostat between 3 and 4. You can make further adjustments to suit your personal requirements after the box has cooled down. Allow the refrigerator to come down to temperature before loading with product. Setting the thermostat to a higher setting i.e. 7, will not decrease the time required for the unit to cool down to its normal operating temperature. AC/DC units cool at the same rate on DC as on AC.

## Defrost & Cleaning:

The frequency of defrost is dependant on the number of door openings, the ambient temperature and the humidity level. Typically, it is a good practice to defrost once there is ¼" of frost buildup on either side of the evaporator (cold plate). When defrosting, the unit is shut off at either the breaker panel or by turning the thermostat counterclockwise to the OFF (0) position. Prop the door open. We suggest placing a towel in the bottom of the refrigerator to catch excess moisture. Speeding up the process with a knife or scraper is strongly discouraged due to the likelihood of rupturing the refrigerant circuit; in the event this happens give us a call 604-523-6515 ext.104.

Now that the unit has been defrosted, the interior can be clean with a non-abrasive cleaner. Do not use "brilo" or "sos" type brasive pads, as they will score the surfaces. Baking soda is recommended.



# Installation Considerations:

## 1. Ventilation:

Ventilation should be one of your first major installation considerations. All refrigerators, regardless of make, are heat transfer machines which transfer heat from the inside of the box thru the evaporator, compressor and refrigerant to the condenser on the outside of the box, to be dissipated to the air. The cavity where the condenser is located **MUST** be adequately ventilated.

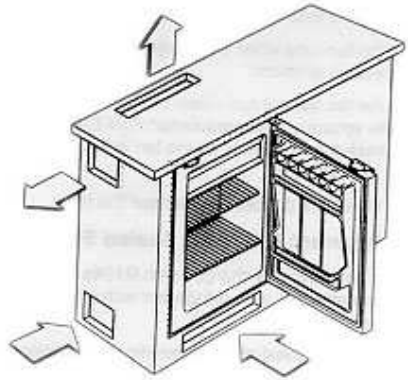

### **Single door units**

Require 30 sq.in. INLET and 30 sq.in. OUTLET

### **Double door units**

Require 60 sq.in. INLET and 60 sq.in. OUTLET

***(With the exception of the RFU9000, and the RFU8220 which has all of the required ventilation built into the front of the flange)***

The INLET should be below the level of the condenser and the OUTLET should be above. This type of ventilation is ideal and will allow natural convection to take place, drawing cool air in low through the INLET, drawing off the heat from the condenser, and allowing the hot air to escape thru the OUTLET. This is how a chimney on a fireplace works.

When using grilles or registers please consider the “free” area as some grilles can be quite large and still be very restrictive. For those inevitable applications that are “hard” to ventilate completely, provisions have been made on the electronic module to accept an auxiliary fan. Please note: adequate ventilation is the responsibility of the installer/customer

## 2. Electrical:

When fitted with the optional AC/DC module, both AC & DC power can be connected to the module at the same time. The unit will always run on AC when AC is available. Should the AC be disconnected there is a 1 minute time delay before the unit continues running on DC. If AC power is reestablished there is no delay, and the unit will immediately resume running on AC.

## 2. Electrical: (cont'd)

The DC models are 12 & 24 VDC (the only consideration is the models supplied with an interior light, either 12VDC OR 24 VDC). The AC/DC models work on both 12 & 24 VDC as well as from 100-240 VAC 50/60hz. (The interior light on the AC/DC models is always 12vdc regardless of the DC supply voltage). Both modules “auto” sense the supply voltages so no wiring adjustments are necessary other than following the guidelines for DC fuse sizing;

### DC breaker & fuse sizing

20-amp breaker (main switch) for both 12 & 24VDC applications

15 Amp fuse for 12VDC

7.5 Amp fuse for 24VDC

### AC (optional) breaker and fuse sizing (100-240VAC 50/60 Hz)

6 Amp breaker (main switch)

4 Amp fuse (included with unit)

## 3. DC Wire Sizing:

Ensuring the correct wire sizing will eliminate premature shut down due to low DC voltage at the refrigerator. Please follow these guidelines.

Nova Kool product is designed to stop running at 10.6 vdc and cut back in at 11.7 vdc, to protect your batteries.

Size AWG Gauge	mm	Max length 12 vdc		Max length 24 vdc	
		ft.	m	ft.	m
12	2.5	8	2.5	16	5
12	4	13	4	26	8
10	6	20	6	40	12
8	10	32	10	65	20

The Max length is from the fridge to the battery.

## 4. Compressor Speed:

All Nova Kool units are supplied with the silent and efficient BD series variable speed compressors from Danfoss. Nova Kool has supplied your unit preset at the optimum speed for most “normal” applications. The speed is controlled by a resistor in the thermostat circuit. 0 ohms (no resistor) runs the compressor on its slowest speed, a 1523 ohm resistor will provide you with the fastest speed. The slower the speed, the lower the amp draw, and the lower the capacity. The chart provides four examples; the resistance must be between 0 ohms and 1523ohms.

Resistor Ohms	Motor Speed rpm	Control Circuit current mA
0	2,000	5
277	2,500	4
692	3,000	3
1523	3,500	2

## AC/DC Wiring diagram

### AC/DC Wiring diagram

## 5. Wiring diagram

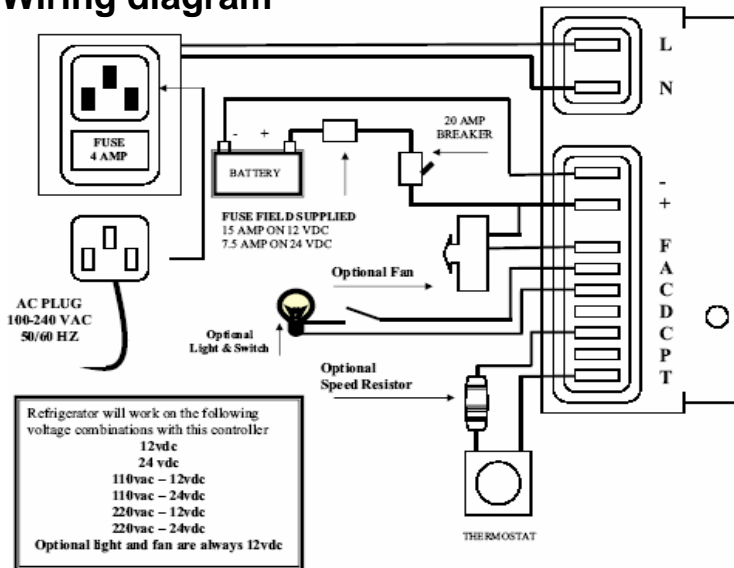

### DC only wiring diagram

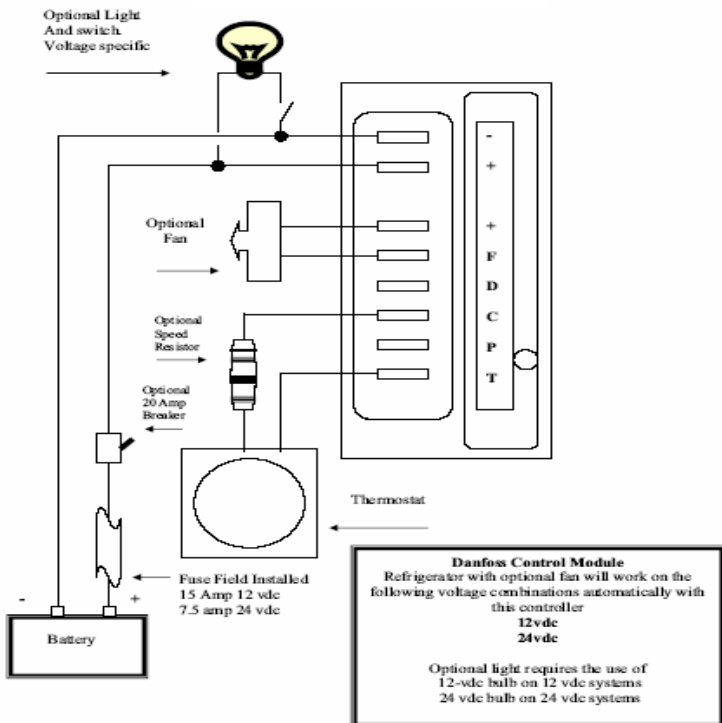

## 6. Installation into the Cabinet:

Nova Kool publishes its cut out dimensions so that the unit will slide easily into the hole. The dimensions allow a little extra space so that the unit can be shimmed into place as well as providing extra air space behind where required. On most models, the mounting screws are installed and covered by supplied frame plugs (see bag with owners manual, ice cube tray & frame plugs). The RFU8000, RFU9000 and flush mounting kits are all installed to the cabinet without screw covers. Please ensure that you are using the correct cut out dimensions that relate to the type of mounting flange you have ordered (flush mounting flanges require an additional 2.25" for the depth and 1" for both the height and the width than the standard units)

## 7. Door Swing:

Most models are shipped standard with the door hung on the right. The door swing can easily be reversed by simply removing the hinge pins and latches and installing them on the opposite side. All of the required hardware is supplied. Units can be factory ordered with the correct door swing (standard is right hinge: i.e. door swings from left to right).

## 8. Door panel:

The decorative door panels can easily be changed to match your interior by first removing the upper hinge pin, then pulling the door out and up. The door should pull off the lower hinge pin easily. Once removed, turn the door upside down and remove the two Phillips head screws. Then, roll the bottom extrusion towards the door gasket, careful so as not to dislodge the door gasket. You will see a ¼" channel where you can slide in your panel material.

## Trouble Shooting

**Check DC operation first then check AC/DC starting at #17**

		YES	NO
1	Turn DC power on and turn thermostat to "7" position	Go to #2	
2	Is the compressor running? (Put your hand on top to feel slight vibration to be sure).	Go to #14	Go to #3

		Yes	No
<b>3</b>	DC Breaker is in the "on" position & optional fuse is good?	Go to #5	Go to #4
<b>4</b>	Replace fuse or turn breaker "on". Does optional fuse or breaker blow?	Go to #6	Go to #5
<b>5</b>	Check voltage at the refrigerator "+" & "-" terminals on the black module. Is it over 12.2 vdc? (or 24.5vdc where applicable)	Go to #7	Go to #6
<b>6</b>	Check batteries, wiring and connections to the refrigerator for fault, corrosion, proper wire sizing and correct the problem.	Go to #1	
<b>7</b>	Put a jumper wire between terminals "C" & "T". Is the compressor running now?	Go to #11	Go to #8
<b>8</b>	Disconnect power. Remove electronic module (Philips screw beside terminal designation label will require removal). Disconnect the plug. Measure resistance (ohms) between each of the three compressor terminal pins. Is the measured resistance APPROXIMATELY the same?(it should be)	Go to #9	Go to #10
<b>9</b>	Replace Electronic Module.	Go to #1	
<b>10</b>	Have compressor replaced by qualified appliance technician who has the ability to evacuate and recharge the system. This is seldom necessary so please be sure and if possible contact Nova Kool for further instruction beforehand.		
<b>11</b>	Check wiring to thermostat with ohm meter to ensure there is continuity. (No broken or damaged wires or connectors). Is the wiring & speed resistor (if so equipped) okay?	Go to #13	Go to #12
<b>12</b>	Disconnect power. Repair or replace wiring or speed resistor (if so equipped) as necessary	Go to #1	
<b>13</b>	Replace thermostat.	Go to #1	
<b>14</b>	Have refrigerator in a well ventilated area (i.e. on cabin floor). After an hour is it refrigerating?	Go to #15	Go to #16
<b>15</b>	Check that adequate ventilation has been provided. 60 sq. in. for single door models and 120 sq. in. for 2-door models. See ventilation suggestion in this manual. Add ventilation as required.		
<b>16</b>	Have a qualified appliance technician determine if there is a refrigerant leak or a compressor with a mechanical problem.		

		Yes	No
<b>17</b>	Switch DC breaker off and AC breaker on. Does the compressor run?	Go to #14	Go to #18
<b>18</b>	Is there 110VAC or 220VAC available the AC plug on vessel?	Go to #19	Go to #23
<b>19</b>	Check Power on the “L” & “N” terminal on the electronic module (see AC/DC wiring diagram in this manual) is there 110vac or 220vac available?	Go to #7	Go to #20
<b>20</b>	Check 4 amp fuse on power plug on refrigerator (see picture), is it good?	Go to #18	Go to #21
<b>21</b>	Replace fuse 4 amp. Did it blow again?	Go to #22	Go to #19
<b>22</b>	Check wiring to “L” & “N” module, Is wire damaged or shorted out?	Go to #24	Go to #9
<b>23</b>	Check plug, wiring, breaker, shore power or genset for damage or fault. Repair or replace as required.	Go to #17	
<b>24</b>	Repair short or damage between plug & electronic module then <b>GOTO #19</b>		

## **Two-Year Limited Warranty**

This refrigeration unit is warranted to be free from manufacturer’s defects in both material and workmanship providing that the unit is used in a manner consistent with the intentions of Nova Kool.

The warranty is in effect from the final sale to the end-user (whether installed in a vehicle or sold separately) for a period of two years. Nova Kool will supply the required replacement part or parts at no charge.

This warranty does not cover problems out of the control of Nova Kool Mfg. inc. including but not limited to acts of God, acts of Government or misuse.

Before calling for warranty please review the troubleshooting in this guide and have your serial # and model # ready.

Our service department can be reached at 604-523-6515 ext 104, or at [support@novakool.com](mailto:support@novakool.com) from 7:00am to 5:00 PST