

Fridge/Freezer Installation and Repair

Introduction

Nova Kool's refrigeration systems are designed to run efficiently from AC Shore Power, Battery Power, or Solar Electric Power.

The refrigerator door is shipped right hinged. This can easily be changed by removing the door pins and latch pin and re-installing them on the opposite hinge bracket. The decorative panel can be easily changed to match the interior of the boat.

The unit is charged with a CFC free R134A. This refrigerant is a Zero Ozone Depleter.

Our unit features a reciprocating compressor which is very efficient; while running it uses less than 60 watt hrs. / hr.

All our refrigerators and freezers have built in battery protection. This feature is designed to help protect the battery from damage due to accidental Deep discharge.



Operation



Our units are easy to operate. We use one thermostat, whether you have a single door or two-door model.

This thermostat is a full range thermostat that will maintain your unit at the temperature you desire. Turning the control all the way to the right (clockwise) will give you the coldest position, and turning to the left will give you a warmer temperature in the fridge. The control is also an on/off switch when you turn it to the "O" position (hard left).

A good setting to start with is #2.

Defrosting

The frequency of defrost depends on the usage, (door openings) and ambient (outside) temperatures. It is time to defrost when the refrigerator builds up 1/4 inch of ice on each side of the cold plates.

The best way to defrost the refrigerator is to remove all the food, and place a towel inside the fridge, on the bottom of the cabinet(s). Turn the thermostat to the "O" position.

Never use a knife to scrape ice from the cold plate. This will rupture the cold plate and let the refrigerant escape.

Cleaning

The best time to clean the fridge is after a defrost. Wipe the inside clean using a non abrasive cleaner(watered down) for the hard to clean stains. We recommend baking soda as the first choice for a cleaner.



If you notice your refrigerator running longer than normal, clean the condenser (usually required every few years).

The condenser is located behind the refrigerator and can be cleaned by using a bottle brush and brushing vertically from top to bottom on the face of the condenser. An alternative method is to vacuum the condenser.



Condenser at back of fridge



[Back to top](#)

Ventilation

All refrigerators, regardless of the make, are heat-transfer machines. They transfer the heat from the inside of the fridge to the outside of the fridge. If adequate ventilation is provided, the compressor will operate more efficiently, and use less power.

The *minimum* total area required for ventilation openings depends on the size of the fridge. All *single* door Nova Kools require 60 square inches of total ventilation area. It is recommended that the vents are located at the bottom (30 square inches) and the top of the fridge (30 square inches); this supports the natural convection of heat from cold (bottom) to warm (top).

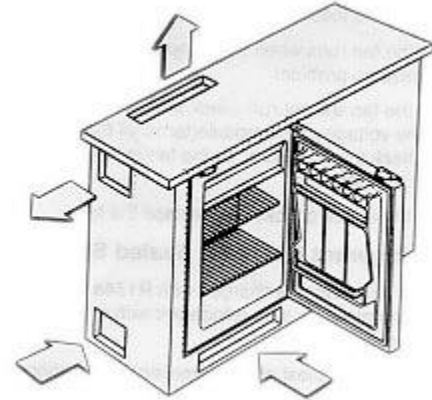

On our double door models, 120 square inches is required (60 at the top and 60 at the bottom). The cold air intake at the bottom of the fridge can be from the left or the right side, and if possible should be at a level below the fridge.

The warm air opening at the top of the refrigerator should be above the fridge if possible. All openings can be of any configuration (long and narrow, square or round) as long as the 60 or 120 square inches is cut out.

If you are using grills, take into account the restriction they will give, and adjust the opening accordingly.



[Back to top](#)

Electrical Hook Up

To determine the size of the wire to be used, measure the maximum length of wire to connect one of the leads from the electronic unit (on the back of the refrigerator) to the battery. Using the chart below, size your wire accordingly. The table is based on a 3% voltage drop.

wire size	max. lead length in feet**	
AWG	12VDC units	24VDC units
14	8	16
12	12	25
10	25	50
8	40	80

** Length is the distance between the electronic unit and the battery

The circuit breaker must be a 20 amp capacity on the DC side and a 5 amp capacity on the (optional) AC side. Failure to size the wire or breaker correctly (too small) may cause a premature shut down of the refrigerator by the Battery Protection Device.

Dual Voltage Electrical Hook up

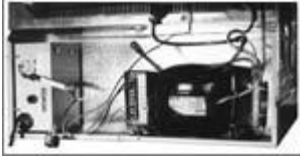

15 Amp Fuse must be Field Wired for 12 volt.
7.5 Amp Fuse must be Field Wired for 24 volt

DC Only Electrical Hook up



15 Amp Fuse must be Field Wired for 12 volt.
7.5 Amp Fuse must be Field Wired for 24 volt

Fuses

We recommend that the refrigerator have its own circuit, without any other appliances connected to the same wires.

Using the Common Buss for the refrigerator wiring can sometimes cause radio frequency noise and interference.



Nova Kool recommends the use of a 15 Amp Fuse (12 VAC) and a 7.5 Amp Fuse (24 VDC) as near as possible to the DC Source.

On the optional AC power supply a 4 amp (110 volt) or a 2 amp (220 volt) glass fuse, can be found under the black fuse holder cap on the power supply.



[Back to top](#)

Power Supply for AC/DC Refrigerators

Wiring Diagram for DC Only Refrigerators

1. Electronic Unit
2. Battery
3. Main switch (optional)
- 4.
5. Fan (optional)
6. Thermostat
7. Resistor for pre-setting compressor speed (optional)
8. Resistor for pre-setting low voltage cut out (optional)
9. Fuse (Field Installed)

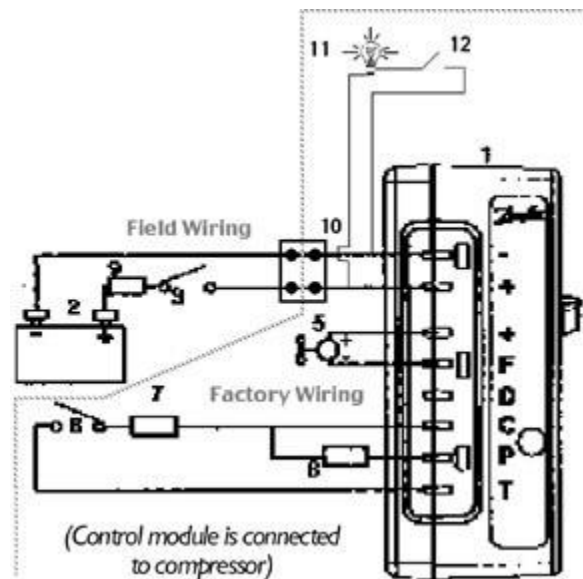

10. Terminal block

11. Light (optional)

12. Door switch (optional)

Standard battery protection settings

12 V cut-out V	12 V cut-in V	24 V cut-out V	24 V cut-in V
10.4	11.7	22.8	24.2

Trouble-Shooting Guide

		Yes	No
1	Turn power on and turn thermostat to "7" position	Go to #2	
2	Is the compressor running? (put your hand on top to feel slight vibration to be sure).	Go to #14	Go to #3
3	DC Breaker is in the "on" position & optional fuse is good?	Go to #5	Go to #4
4	Replace fuse or turn breaker "on". Does fuse or breaker blow?	Go to #6	Go to #5
5	Check voltage at the refrigerator "+" & "-" terminals on the black module. Is it over 12 VDC?	Go to #7	Go to #6 - (Go to 17 on AC/DC models)
6	Check batteries, wiring and connections to the refrigerator for fault, corrosion, proper wire sizing and correct the problem.	Go to #1	
7	Put a jumper wire between terminals "C" & "T". Is the compressor running now?	Go to #11	Go to #8
8	Disconnect power. Remove electronic module (philips screw beside terminal designation label will require removal). Disconnect the plug. Measure resistance (ohms) between each of the three compressor terminal pins. Is the measured resistance APPROXIMATELY the same?	Go to #9	Go to #10
9	Replace Electronic Module.	Go to #1	
10	Have compressor replaced by qualified appliance technician who has the ability to evacuate and recharge the system. This is seldom necessary so please be sure and if possible contact Nova Kool for further instruction beforehand.		
11	Check wiring to thermostat with ohm meter to ensure there is continuity. (No broken or damaged wires or connectors). Is the wiring okay?	Go to #13	Go to #12
12	Disconnect power. Repair or replace wiring as necessary	Go to #1	
13	Replace thermostat.	Go to #1	
14	Have refrigerator in a well ventilated area (ie. on cabin floor). After an hour is it refrigerating?	Go to #15	Go to #16
15	Check that adequate ventilation has been provided. 60 sq. in. for single door models and 120 sq. in. for 2-door models. See ventilation suggestion		

on Page 3 of this manual. Add ventilation as required.

16	Have a qualified appliance technician determine if there is a refrigerant leak or a compressor with a mechanical problem.		
FROM 17-24 APPLIES TO AC/DC MODELS ONLY			
17	Switch DC breaker off and AC breaker on. Does the refrigerator run?	Go to #18	Go to #19
18	Turn DC breaker on and check DC voltage on Terminal Block located on side of grey AC power supply. Is it above 12 VDC (or 24VDC)?	Go to #24	Go to #6
19	Check fuse on grey AC power supply (4 amp 110V and 2 amp 220V). Is the fuse good?	Go to #22	Go to #20
20	Remove power supply and determine if there are any indications of a short circuit. If no, replace fuse. Does fuse blow again?	Go to #24	Go to #21
21	Check DC voltage output of power supply at black module terminals "+" & "-". Is it above 12 VDC (or 24 VDC)?	Go to #18	Go to #24
22	Is 110V (or 220V) available at the AC plug?	Go to #21	Go to #23
23	Check plug, wiring, breaker, shore power or genset for damage or fault. Repair or replace as required.	Go to #17	
24	Replace grey AC power supply.		



[Back to top](#)

Typical AC/DC Refrigerator

1. Electronic Unit
2. Battery
3. Main switch (optional)
4. Power Supply (optional)
5. Fan (optional)
6. Thermostat
7. Resistor for pre-setting speed
8. Resistor for pre-setting battery protection voltage (optional)
9. Fuse
10. Terminal Block
11. Light (optional)
12. Door Switch (optional)

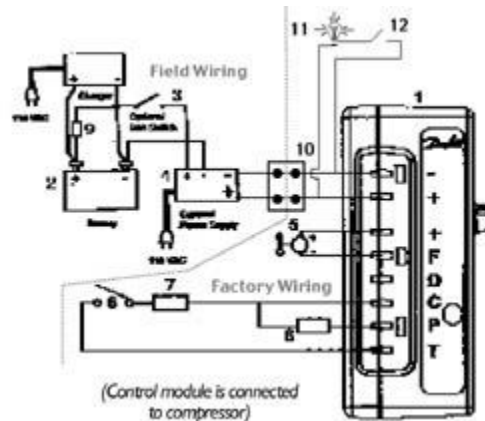

13.

Refrigerant Charge & Sealed System

Your Nova Kool is charged with R134a. This is an environmentally safe refrigerant with a "O" Ozone Depletion Potential.

It is used by most of the domestic refrigeration and appliance repair companies and manufacturers.

If you need to repair the closed sealed system, use a qualified appliance refrigeration person. This is seldom necessary so be sure first, and before any arrangement is made contact Nova Kool.

Operational Sequence

When the thermostat is turned on (you should hear a click) the compressor should try to start. It is not uncommon to hear a small squeak when it tries to start. If it does not start on the first attempt it will continue to try every 40 seconds. If, for some reason, the compressor becomes overloaded it will go through this cycle and the fan will continue to run during the 40 seconds.

When the thermostat is satisfied, the compressor and fan (optional) shut down.

Before doing warranty work contact your dealer or Nova Kool at (604) 523-6515.