

# Remote Installation & Trouble Shooting Guide Pre Nov. 1998

## Introduction

Nova Kool's refrigeration systems are designed to run efficiently from AC Shore Power, Battery Power, or Solar Electric Power.

The Nova Kool custom refrigeration system includes the following:

1. condensing unit c/w compressor, fan cooled condenser, and reusable quick connect fittings.
2. an evaporator (cold plates) made up of three plates. The plates come complete with a capillary tube, heat exchanger, refrigerant lines (12') and quick connect fittings to attach to the condensing unit. It is available in two models; the RT6 freezer box or the "F" Plate configuration.
3. the third component to complete the installation is the system thermostat. The enclosure c/w thermostat and knob can be mounted inside the refrigerator or out, but the small diameter sensing tube must be attached to the cold plates inside the fridge or freezer.



The unit is charged with a CFC free (R134a) refrigerant. This refrigerant is a Zero Ozone Depleter.

Our unit features a reciprocating compressor which is very efficient. While running, it uses less power than a 60 watt light bulb.

This unit has built in battery protection. This feature is designed to help protect the battery from damage due to accidental deep discharge.

## Operation

Our units are easy to operate. The temperature inside your refrigerator is controlled by the thermostat. This thermostat is a full range thermostat that will maintain your unit at the temperature you desire. Turning the control all the way to the right (clockwise) will give you the coldest position, and turning to the left will give you a warmer temperature in the fridge. The control is also an on/off switch when you turn it to the "O" position (hard left). A good setting to start with is #2.

## Defrosting

The frequency of defrost depends on the usage, (door openings) and ambient (outside) temperatures.

It is time to defrost when the refrigerator builds up 1/4 of an inch of ice on each side of the cold plates.

The best way to defrost the refrigerator is to remove all the food and place a towel inside the fridge on the bottom of the cabinet(s). Turn the thermostat to the "O" position.

Never use a knife to scrape ice from the cold plate. This will rupture the cold plate and let the refrigerant escape.

## Cleaning



The best time to clean the fridge is after a defrost. Wipe the inside clean using a non abrasive cleaner(watered down) for the hard to clean stains.

We recommend baking soda as a cleaner.

The condenser may collect lint and dust on the fins. If you notice your refrigerator running longer than normal, clean the condenser (every few years). The condenser is located on the condensing unit base, and can be cleaned by using a bottle brush and brushing vertically from top to bottom on the face of the condenser. An alternative method is to vacuum the condenser. Be very careful not to damage the fins because they are aluminum and will bend easily.



[Back to top](#)

## Ventilation

All refrigerators, regardless of the make, are heat-transfer machines. They transfer the heat from the inside of the fridge to the outside of the fridge. If adequate ventilation is provided, the compressor will operate more efficiently, and use less power .

If the compressor is installed in a hot room (engine room) , it should be located in the open with no enclosure to obstruct air flow to the unit, or cause condenser air to be re-circulated.

If the unit is mounted in a closed area (cupboard or locker), there must be two holes provided; one for cool air to be pulled in by the fan and the other to allow the warm air to vent from the enclosure. The size of the opening must be at least 7"x7". The inlet must be ducted(separate passageway) so the air is drawn through the condenser and blown across the compressor.

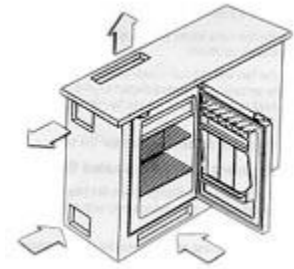

If a decorative grill is to be placed over any of the ventilation openings the size of the opening must be increased in order to still provide 50 sq. inches of free unobstructed area.

To test the effectiveness of the ventilation, measure the exhaust air inside the enclosure. The temperature should be no more than 5 degrees higher than the air entering the enclosure(ambient air temp).



[Back to top](#)

## Electrical Hook up

To determine the size of the wire to be used, measure the maximum length of wire to connect one of the leads from the electronic unit (on the back of the refrigerator) to the battery. Using the chart below, size your wire accordingly. The table is based on a 3% voltage drop.

Wire Size AWG	Max. lead length in feet**	
	12 VDC units	24 VDC units
14	8	16
12	12	25
10	25	50
8	40	80

\*\* Length is the distance between the electronic unit and the battery

The circuit breaker must be a 20 amp capacity on the DC side and a 5 amp capacity on the (optional) AC side.

Failure to size the wire or breaker correctly (too small) may cause a premature shut down of the refrigerator by the Battery Protection Device.

We recommend that the refrigerator have its own circuit, without any other appliances connected to the same wires.

Using the COMMON BUSS for the refrigerator wiring can sometimes cause radio frequency noise and interference.



## FUSES

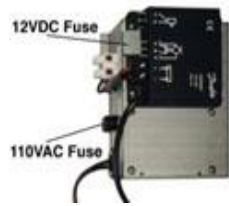

Nova Kool refrigerators use a 15 amp (12 volt) and a 7.5 amp (24 volt) in the electronic unit. This fuse can be found under the gray plastic cap on the electronic unit.

On the optional AC power supply a 4 amp (110 volt) or a 2 amp (220 volt) glass fuse, can be found under the black fuse holder cap.

### Electronic unit and power supply (AC/DC)

*NOTE: Most LT200-F and LT200-RT6 are supplied*

*DC only - without power supply*

- 8 – Battery
- 9 – Module (electronic unit)
- 11 – Fuse 12VDC 15 amp, 24 VDC 7.5 amp
- 12 – Thermostat
- 13 – 20 amp breaker
- 14 – Air cooled fan (Optional)
- 15 – Low voltage diode (N/A)
- 16 – Light (optional)
- 17 – Light fuse 15amp (if unit has a light)

### Wiring diagram for DC only Refrigerators

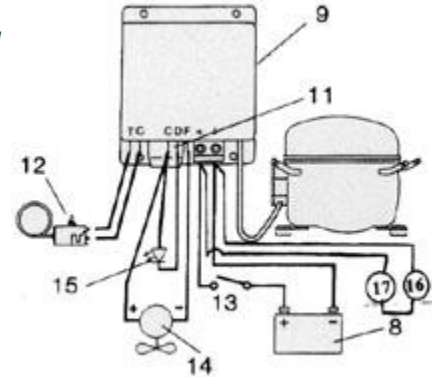

[Back to top](#)

## Trouble-Shooting Guide

If your Nova Kool fails to run, check all the electrical items exposed to the marine environment. In the case of a new refrigerator, these are also the items most likely to be damaged by transport and rough handling.



1. Check the fuse located under the gray cap, below the DC connections on the module. Reverse polarity will cause this to blow.
2. Check the voltage at the electronic module. On 12 volt systems the voltage should read 12.0 volts minimum, with the battery charger turned off.
3. If you don't read over 12.0 volts check the following:
  - condition of batteries and state of charge
  - Wire size and connections
  - If the circuit has a breaker it must be size 30 for 20 amps capacity.
4. a) Check the thermostat by removing the wire from the terminal marked "T." If this is the only time the unit stops running we know the thermostat has failed.  
  
b) Take a short piece of wire and jumper between "T" and "C". If this starts the compressor we then know that the thermostat circuit is faulty. Replace the thermostat or the faulty wiring that connects the thermostat to the module.

*Note the compressor runs very quietly. Hold your hand on top of the compressor to tell if it is running.*

If you hear a small squeak when the compressor starts "this is normal".

5. Check the electronic module. This device is responsible for all electronic functions. These include motor commutating, battery monitoring, fan power(optional), and all safety functions.

The module is not field repairable and can be checked out by sending it to Nova Kool.

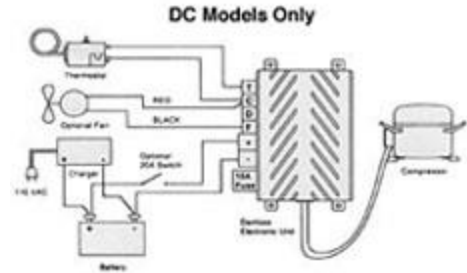

6. To check the compressor's internal windings, ohm the following terminals.



[Back to top](#)

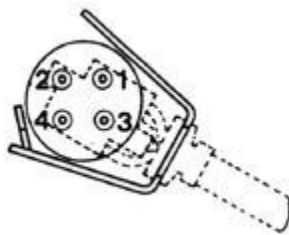

**Plug Colors:**

- 1 - Black
- 2 - White
- 3 - Brown
- 4 - Blue

	12 VDC	24 VDC
Terminals 1 to 3	0.3	0.7
Terminals 4 to 3	0.3	0.7
Terminals 2 to 3	3.5	3.5

**NEVER CONNECT POWER DIRECTLY TO COMPRESSOR!**

7. If your fridge has our optional AC/DC converter, check the following, (usually not sold with LT200-F & LT200-RT6 systems):
  - the glass fuse under the fuse cap (110 volt 4 amp - 220 volt 2 amp)
  - check the AC power supply to the converter
  - Check the DC out put (12.5-14.5) volts DC

This unit can be replaced as an assembly.

Diagram shows older style Electronic Unit.

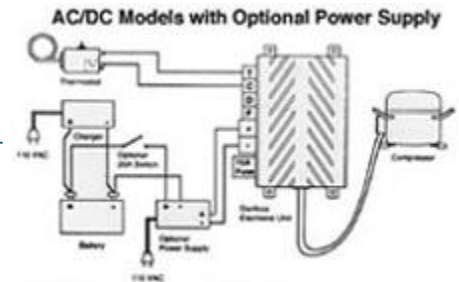

8. The fridge has an air fan, check the following:
  - if the fan runs when the compressor runs, you have no problem
  - if the fan will not run, check the connections and the voltage at the module (terminal C-F) and check the connector on the fan motor to ensure that it is plugged in. (red to + and always on C)
  - if the above checks out, replace the fan.

**Refrigerant Charge & Sealed System**

Your Nova Kool is charged with R134a. This is a environmentally safe refrigerant with a "O" Ozone Depletion Potential.

It is used by most of the domestic refrigeration and appliance repair companies and manufacturers.

If you need to repair the closed sealed system, use a qualified appliance refrigeration person. This is seldom necessary so be sure first, and before any arrangement is made contact Nova Kool.

### Operational Sequence

When the thermostat is turned on (you should hear a click) the compressor should try to start. It is not uncommon to hear a small squeak when it tries to start. If it does not start on the first attempt it will continue to try every 40 seconds. If, for some reason, the compressor becomes overloaded it will go through this cycle and the fan will continue to run during the 40 seconds.

When the thermostat is satisfied, the compressor and fan (optional) shut down.

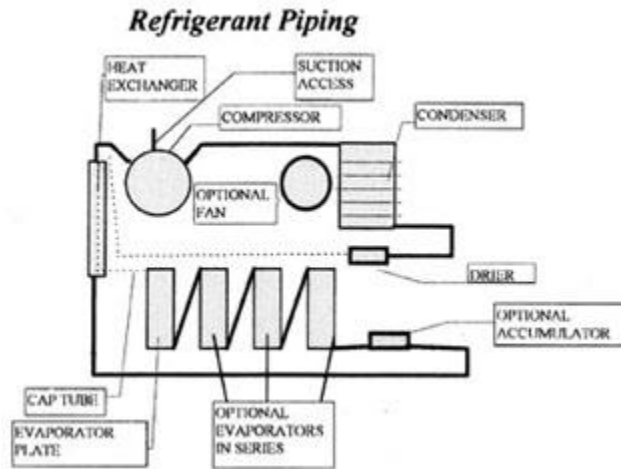

### Installing the cold plates

#### "F" Plates or the RT6 Freezer Box

Most custom marine refrigerators are designed top opening because cold air is heavier than warm air. With this design the door can be left open without significantly increasing the temperature in the freezer. For the same reason, the cold plates must be mounted with their top edges near the top of the refrigerator, on the interior wall.

Cooling will only take place below the top portion of the cold plates.

Nova Kool systems are designed to work as a freezer or as a refrigerator. Turn the thermostat "warm" and the space becomes a refrigerator. Turn the thermostat "cold" the space becomes a freezer (providing the space is not too large).

To use our system for a fridge/freezer combination, mount the cold plates in the section designed as a freezer. Install a 1" insulated partition between the fridge and the freezer, with a variable sized hole in the bottom (approximately 1-1/2" round).

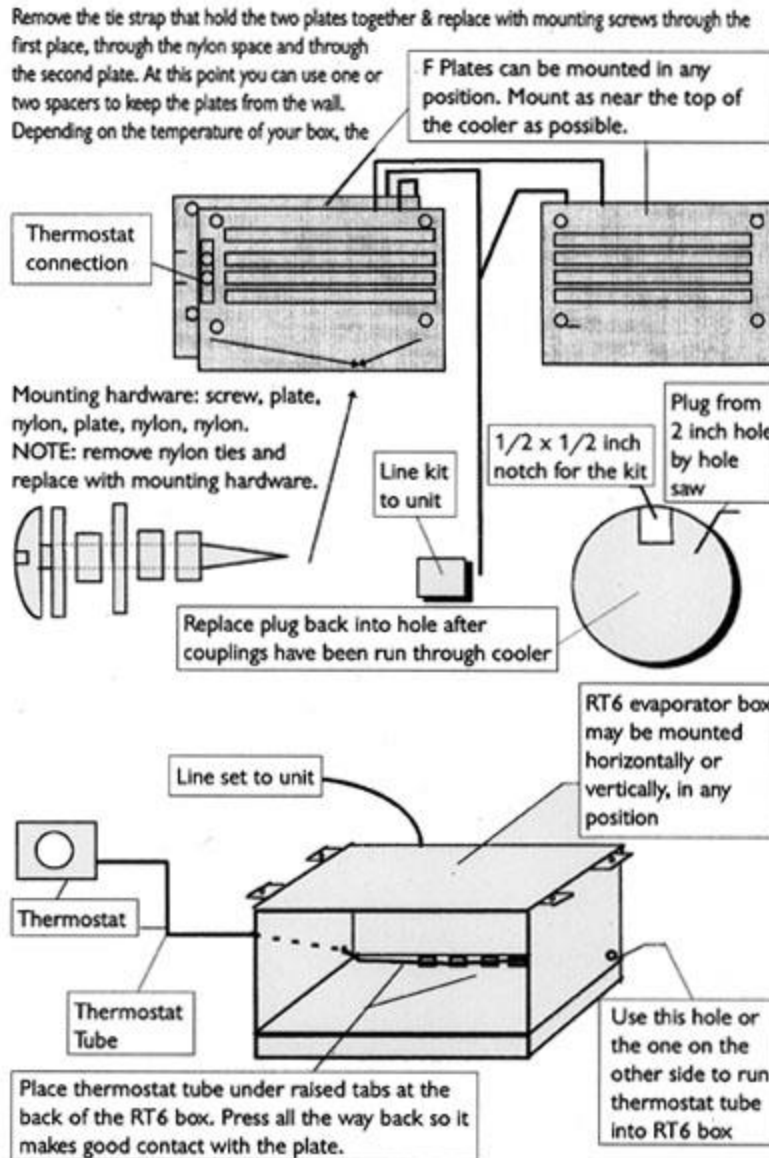

[Back to top](#)

This hole will allow the cold freezer air into the refrigerator side of the cooler, and as the air warms it will rise over the top of the partition and start the natural circulation flow over again.

**The size of your refrigerator or freezer area that you are able to refrigerate, will depend upon the amount of insulation surrounding the enclosure.**

The RT6 Freezer box can be mounted horizontally or vertically: the higher it is placed in the cooler the more efficient the refrigerator will operate. Mounting upright is much more convenient.

## Installation Check List

1. Select a location for the LT200 condensing unit. The lines are 12 feet in length. Check the laying length into the refrigerator, make sure you have not mounted the evaporator further from the unit than the line set will allow. Position the unit so the electrical connections and the quick connect

fittings are easily accessible. You will have to tighten the refrigerant line quick connect to the condensing unit line quick connects so leave room to swing two large wrenches.

2. Design your ventilation system. If it is necessary you can install an extra fan (same type as the one on the unit) to terminals F & C. If you use an extra fan it will use approximately 3 watt hrs./hr. and run only when your unit runs.



Shows Nova Kool RT6 mounted near the top of the freezer section.

3. The "F" Plate evaporator plates are connected together with tubing to allow an 18" spread width. They can be mounted across from each other or adjacent to one another inside the cooler. They should be mounted 1" from the interior top side of the refrigerator. The plates can be mounted in any physical position. When the plates are permanently mounted, make sure the copper tube is not touching the aluminum tube due to electrolysis.
4. Make a cardboard template from the cold plate mounting holes and select the mounting position for both F plates (or single RT6 assembly). The copper tubing should remain coiled. Next, select the most convenient location for the tubing exit hole. Drill a 2 " hole using a hole saw.



Shows Nova Kool LT200 installed in ventilated lazarette.



[Back to top](#)

5. Uncoil the tubing and feed the couplers and copper tubing through the hole, to the outside of the refrigerator. Fasten the plates using the spacers and screws provided, to the area previously marked.

Use a minimum of one spacer to keep the evaporator plates away from the cooler wall.

6. Starting just inside the refrigerator, the foam tubing should run on the outside of the tubing in a direction towards the condensing unit. The exit hole must be sealed air tight on the outside and fit loosely on the inside, with fiberglass insulation in between.

Moisture always moves to the coldest point; this is why it is important to seal on the outside of the tubing hole. Also insure the interior liner of the fridge is sealed on all lower seams in order to prevent defrost water from leaking into the insulation.

7. Carefully and neatly run the tubing to the condensing unit. Make long radius bends if possible. To make a tight bend of 90°, support the copper with both thumbs while making the bend. Excess tubing can be rolled back up and stored out of the way, (do not cut the tubing, it has a refrigerant charge in it). Make as few bends in the tubing as possible because it work hardens with each bend. Three bends are usually considered maximum.
  
8. Connect the "quick connects" from the line set to the condensing unit. They are male and female and impossible to connect backwards. The connectors are designed to be put together and taken apart with out the loss of refrigerant. (Do not be disturbed to see wrench marks on the connectors, because we connect them during our 12 hour unit test run.)

To connect:

- a. put a small amount of oil or WD40 on the male coupling, and between the swivel part of the female nut.
- b. connect and turn by hand till tight, (approximately 2 turns).
- c. use two 12" crescent type wrenches to tighten couplings together. Be sure not to let the copper tubing turn, or the unit will be damaged.

Use one wrench on each side of the coupling.

9. The thermostat is installed in a small white box and is complete with 14' of wire. The thermostat connects to C & T on the module (polarity does not make any difference with the thermostat, but it does with all other connections)

You can mount the thermostat box inside or outside the refrigerator space, but the last 2" of the 48" sensing line must be connected to the cold plates. Connect the sensing tube to the cold plate by placing 2" of it under the 1"x2 " plate on the second cold plate.



[Back to top](#)

## Nova Kool LT200-RT6 & LT200-F REMOTE

**Features:**



- small foot print for easy mounting
- 3 plates for maximum capacity
- thermostat controlled for a wide range of settings
- powder coated galvanized base is corrosion resistant and easy to clean
- fan cooled condenser increases efficiency
- DC compressor is quiet, vibration free, safe and dependable
- pure DC unit minimizes RF noise and Electrolysis
- designed to operate at a constant angle of 30 degrees
- unit is shipped with everything you need to complete the installation

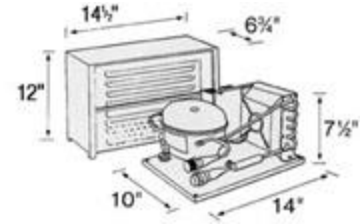

**LT200 RT6**

**Models:**

LT200 RT6 & LT200 F	12 Volt DC Only
Optional Remote Mount Power Supply	110 VAC (60 Hz) or 220 VAC (50 Hz)

**Specifications:**

Refrigerant	R134A	
Charge	6.0 oz.	
Weight	38 lbs.	
Voltage	12 or 24 vdc	
Options	110 or 220 vac	
Low voltage battery protection	Yes	

**LT200 F**

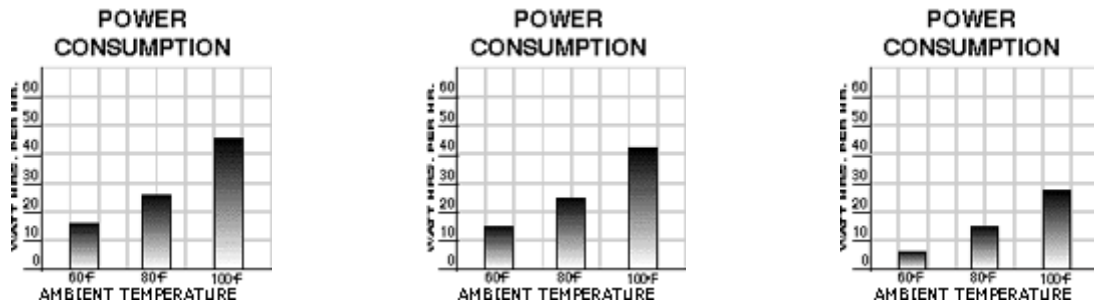

All Power Consumption Graphs based on 7.5 cu. ft. size, insulated with 2" Urethane Foam or 3" Polystyrene Foam.

Before doing warranty work contact your dealer or Nova Kool first. For more information call your local dealer, or **Nova Kool at 604-523-6515**